



HELLER
Machines

HELLER Machines. Made to work.

www.heller-machinetools.com

HELLER
Automotive

Inside Competence.

Our extensive know-how allows us to offer innovative and comprehensive production solutions for powertrain, drivetrain and chassis components. Highly productive. For minimal piece-part costs.

HELLER
Machines

Made to work.

Application know-how and technological competence to cater for all production requirements. With a new generation of machining centres offering a wide range of options in our proven quality.

HELLER
Services

Just closer to you.

Individual services and custom-made service packages ensure optimum productivity and highest availability of your machines. Anywhere in the world, on site and around the clock.



HELLER
Machines

HELLER Machining Centres

The new H 5000 / H 6000
For high-performance cutting



HELLER Machines:
Made to work. 3

The H series:
one for all 4

Machine concept:
H 5000 / H 6000 6

Simply more HELLER:
extensions and options 10

Operation:
proven and perfected 12

Maintenance:
done in a flash 13

Made to work.

Horizontal machining centres with the productivity seal of approval

You know HELLER. HELLER stands for high-end machining with maximum productivity. HELLER Machines benefit from the know-how and experience gained through many decades in the manufacture of machining centres. Let us show you how you can profit from our experience – you can only win!

When you're dealing with challenging manufacturing tasks, you want all the solutions from one source. HELLER Machines has the answer to your needs. Due to our comprehensive application know-how and high level of technological competence we can provide solutions for all requirements of modern production. A new generation of versatile machining centres with a wide range of options rounds off our product range with a clear focus on our customers' needs whilst always providing the typical extra quality from HELLER: a plus in productivity, security and flexibility.

HELLER Machines aims to build machines precisely tailored to your production needs. With this aim in mind we have now transformed and refined our business portfolio for you.

There's a lot we can do for you. Let's get started!

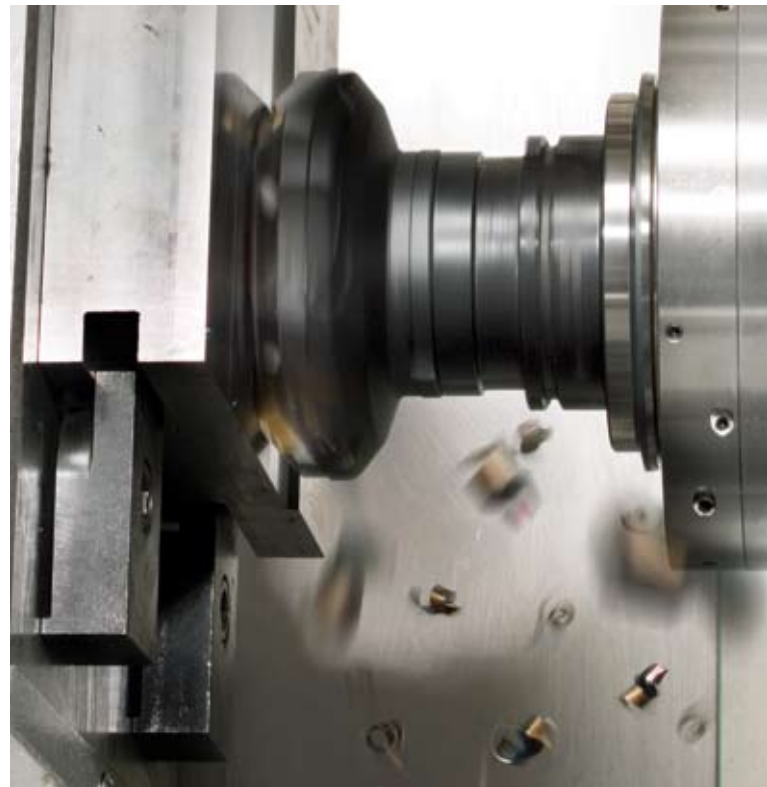

The H series: one for all





You need machining centres that can be fully customised to your requirements whilst offering an attractive price/performance ratio and the confidence that they will produce reliably even under extreme loads. Therefore our task was to develop a range of highly standardised but flexible machines with unbeatable load capacity.

Tailor-made off the peg

Due to the modularity of the variants and options available for the new H series, customers can configure their own “tailor-made off the peg” machining centre. Spindle, spindle taper, tool magazine, chip disposal can be selected according to individual requirements and machining strategy. With options proven in everyday production HELLER machining centres can be transformed into customised performance packages.

Realistic dynamic rates

All machines from the new H series have one thing in common: they offer unbeatable productivity. The machines have been adequately designed to provide minimal positioning times. Consequently the H series can do without extreme rapid traverse and acceleration rates, so that the machines are not unnecessarily subjected to extreme loads. This enhances the machine life and provides additional savings.

Robust processes

Gaining a few tenths of a second is not what makes the difference, what counts is that production runs smoothly. The new H series was designed for stable processes in day-to-day production: proven components, adequate speeds and a wide range of standard equipment that can be extended with numerous options. In brief: a robust machine that can be run at full load even to the limit, seven days a week in 3-shift operation.

Machining at its best

HELLER is synonymous with milling. For us that is a promise and commitment at the same time. Whether it's high-speed cutting, heavy cutting, dry or MQL machining: the machining centres from the H series are suitable for any machining strategy and provide high productivity throughout all disciplines.

Application experience you can feel

Reliability and ease of operation are important factors for availability. With the H series you can benefit from our application experience every day – whether it's the workpiece setting station, tool loading or programming. We have also completely revised the maintenance concept for the H series, a factor that has a crucial influence on the lifecycle costs of a machine.

HELLER's H series – a bit more of everything.

Machine concept H 5000 / H 6000



Sizes H 5000 / H 6000

- X = 800 mm / 1,000 mm
- Y = 800 mm / 1,000 mm
- Z = 800 mm / 1,000 mm

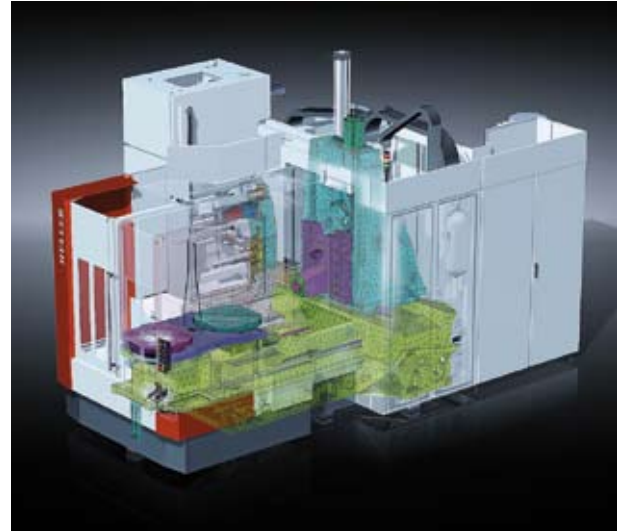
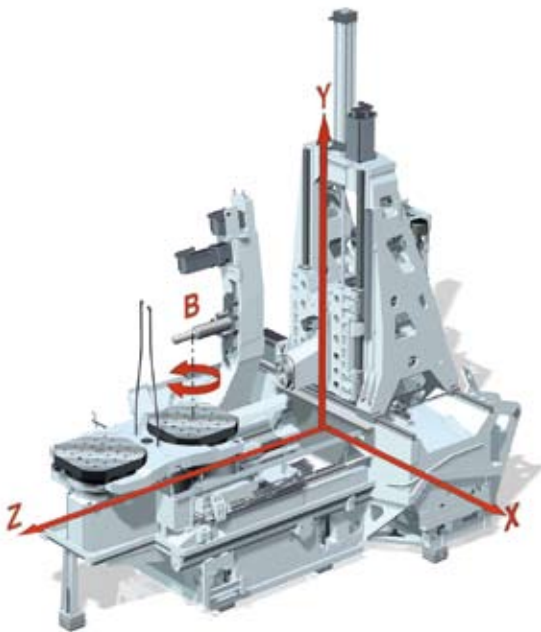

Machine bed and column

Optimised with state-of-the-art simulation technology

- Optimised topology of structural components resulting from many years of experience from in-house simulation
- Inherently rigid machine bed
- Cast and steel components, e.g. beds, columns and rotary tables, designed to provide rigidity

The benefits to you:

- Installation without anchoring ensures high flexibility for machine installation
- High cutting performance and precision for every machining strategy
- Cost-effective price
- Short commissioning times

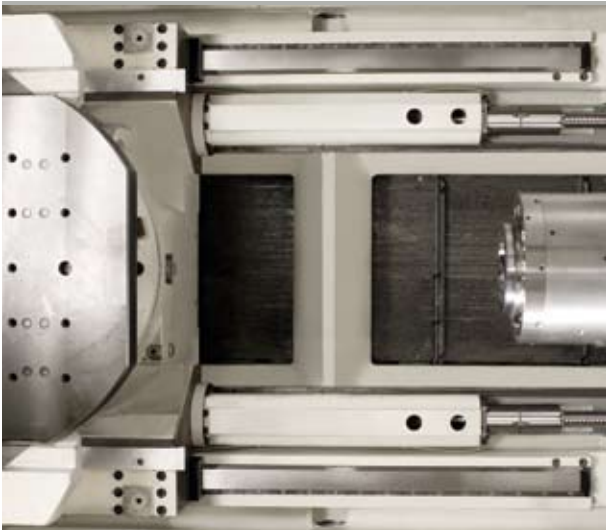

Drive technology

Enhanced power and precision

- Twin drive in the Z-axis for symmetric force application and free chip fall
- Ball screw drives arranged in-between linear guideways
- Reduced performance demands on the individual ball screw drives at ultra-short positioning times
- Max. rigidity of the drive train and high positioning accuracy

The benefits to you:

- High precision thanks to twin drive in Z-axis
- Reduced table deformation and higher precision with drives arranged on the inside
- Minimal axes positioning times ensure high productivity
- Reduced wear for low operational cost



Spindle

Highest precision made by HELLER

- Proven zero-spindle system based on extensive HELLER know-how
- Maintenance-friendly, modular spindle unit
- In-house manufacturing competence ensures highest quality
- High accuracy due to precision cooling
- 4 spindle variants for PowerCutting, HighPowerCutting, SpeedCutting and PowerSpeedCutting
- Clear spindle nose allows extended reach into the workpiece
- Innovative coolant purging for spindle and tool
- Spindle tapers: SK 50, HSK 100, BT 50

The benefits to you:

- Zero-spindle system ensures fast and cost-effective exchange of the spindle
- Stiff spindle nose for high process stability
- Dynamically stiff, short design of the spindle unit and water-cooled spindle neck provide high precision
- Reduced coolant dispersion provides cleaner machine and tools

Machine concept H 5000 / H 6000



Work area

Free chip fall, higher accuracy

- Free chip fall below the spindle and between rotary table and pallet changer, steep chip chutes in work area and setting station
- Scraping conveyor 600 mm wide covering the complete Z-stroke
- Minimal chip accumulating surfaces, e.g. rotary table has integrated motor
- Cooling channels inside the tool are purged after use of internal coolant, functional surfaces at the rotary table and setting station are air-blasted
- No swarf dispersion from the machine bed since covers do not exit the work area
- Bright work area lighting

The benefits to you:

- Reduced downtimes due to contamination, extended cleaning intervals
- Reduced production costs
- Higher workpiece precision



Space requirements

Smaller footprint, reduced costs, faster installation

- Components and units fully integrated into the machine structure
- Very compact control cabinet, identical for all machine types
- Compact design provides very small footprint in this machine range
- Installation without anchoring on vibration-damping levelling shoes
- Low overall weight

The benefits to you:

- Reduced space and foundation requirements save infrastructure costs
- Machine easier to relocate due to quick and easy installation
- Good vibration insulation provides enhanced machining accuracy



Workpiece management

More space, less chip deposits

- Rigid rotary table with two separate Z-axis guideways
- New brake system provides high clamping force in the B-axis of the rotary table
- High workpiece mass of up to 1,400 kg
- Optional hydraulic workpiece clamping via 5-point services interface with 60/200 bar
- Air blast for functional surfaces (rotary table and setting station)
- Pallet changer with reduced chip accumulating surfaces
- Friction-locked 4 x 90° indexing at the setting station with foot release

The benefits to you:

- Machining of large workpiece geometries and masses
- High process stability thanks to new rotary table clamping
- Compact rotary table provides optimised chip flow
- High machining accuracy through reduced chip deposits and pneumatic cleaning
- Maintenance of stationary hydraulic valves outside the work area



Tool management

Customised to your requirements

- Tool changer with two independent servo-axes for shortest chip-to-chip times
- Chain-type tool magazine with 50 places as standard, optional chain-type magazine with 100 places
- Rack-type magazine for high tool storage capacity
- Tool lengths up to 600 mm, tool diameters up to 280 mm
- Fast tool break monitoring with reference measurement (option)
- Tool coding (option)

The benefits to you:

- Wide range of tools and tool geometries
- Re-use of existing cutting tools
- New operating strategy for short tool loading times
- Short idle times due to optimised chip-to-chip times
- Tool condition monitoring minimises downtimes

**Adequate power for
each operation**

Spindle

**Different spindle versions
for high productivity**

Workpiece management

**Quick and easy handling
of large workpieces**

Tool management

**Customised to your
requirements**

Machine dynamics



Spindle

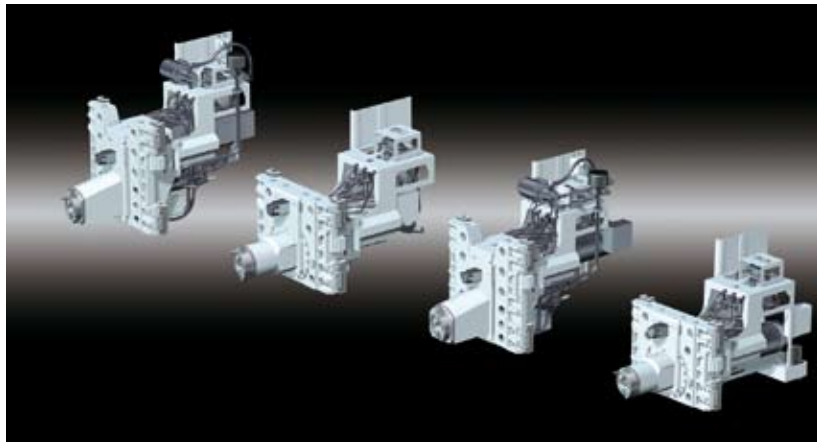

Workpiece management

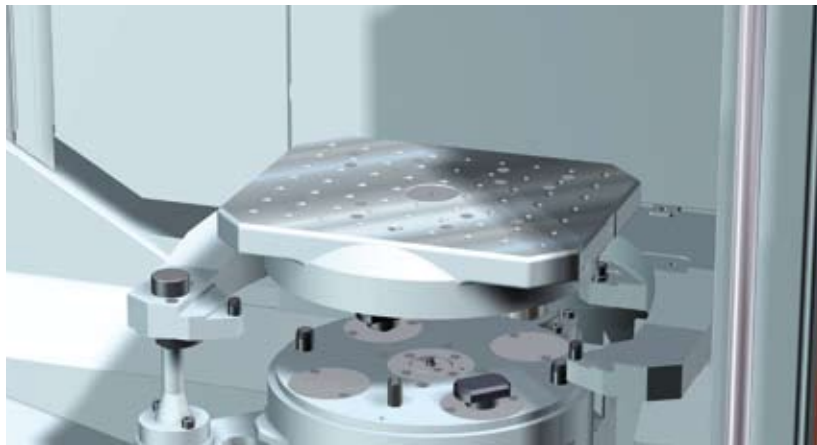

Tool management



- 2-axis servo-changer provides shortest chip-to-chip times
- Increased axis dynamics through adequate drive dimensioning
- High rapid traverse rates (up to 60 m/min) and accelerations (up to 7 m/s²)

Extensions and options typical extra quality from

- PowerCutting: 8,000 1/min / 43 kW / 822 Nm
- SpeedCutting: 12,500 1/min / 52 kW / 166 Nm
- HighPowerCutting: 6,000 1/min / 60 kW / 2,292 Nm
- PowerSpeedCutting: 12,500 1/min / 52 kW / 500 Nm

- High clamping force in the B-axis
- High workpiece mass of up to 1,400 kg
- Friction-locked 4 x 90° indexing at the setting station with foot release
- Automatic rotating setting station and automatic setting station door
- 60 bar or 200 bar hydraulic workpiece clamping
- 200 bar workpiece clamping with proportional control
- Pallet change possible when pallet changer bridge is lifted

- Chain-type magazine with 50 or 100 places
- Rack-type magazine with 260 or 420 places
- Optional cleaning of tool cartridges and holders
- Tool loading to chain-type magazine parallel to machining via automatic traverse attachment
- Fast tool break monitoring with reference measurement



Options: m HELLER



- Siemens SINUMERIK 840D solution line or Fanuc 310i-A
- Increased operator convenience
- Pallet and job management
- Automatic return to home position
- Operating modes 2 and 3 included in standard scope of supply
- Graphical diagnostic tools
- Remote diagnostics of the machine and coolant unit
- Comprehensive option package

- Standardised interface to linkage systems
- Automation with pallet pool or pallet magazine:
 - PP – pallet pool, up to 6 pallets
 - PMB – linear pallet magazine, up to 24 pallets
 - PME – modular expandable pallet magazine, up to 42 pallets
 - PMF – customisable pallet magazine with wide range of functions
- Robot automation:
 - Automation with drawer-based and skid-based workpiece-carrier system
 - Automation by means of conveyor and paternoster system

- Basic design with chip conveyor (SPF)
- High pressure paperband filter (PBF) 50 or 70 bar, 40 µm filtration quality
- Vacuum rotation filter (VRF) with high-pressure pump 50 or 70 bar, 40 µm filtration quality
- Extraction unit for emulsion on the work area cover
- Work area flushing
- Coolant cooler

- Multi-spindle head location
- Measuring probe
- Minimal quantity lubrication with single-channel MQL unit
- Facing slide attachment through the centre of the spindle HSK 100
- Additional hydraulically operated clamping for critical operations or tools
- Tropical package for ambient temperatures up to 45° C and high humidity

Control



Automation

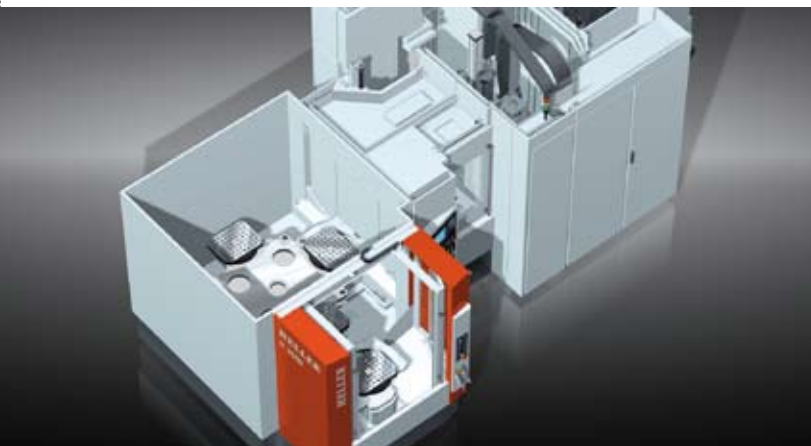

Chip disposal

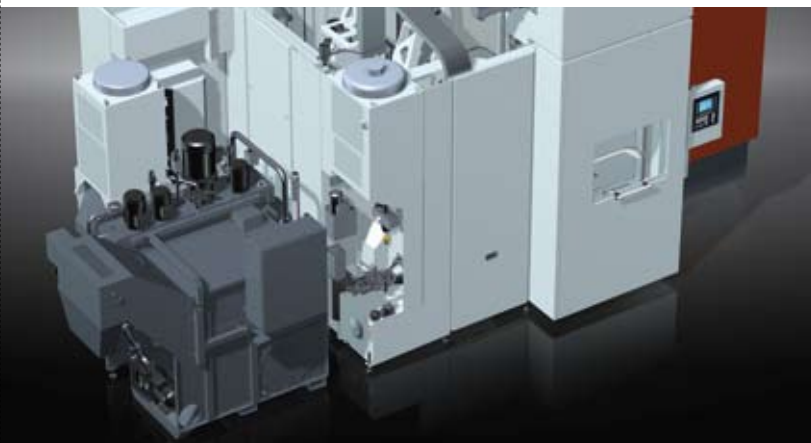

Auxiliary equipment



State-of-the-art high-end control technology

For flexible integration into manufacturing systems

The perfect solution for all strategies

Ready for all requirements of day-to-day production

Operation: proven and perfected

Scores well for everyday use

The productivity of a machine tool is defined by its cutting performance and reliability, while safety and ease of operation play a major role for its availability. With the H series you can profit from our application experience day in and day out.

The operating stations of the machine are arranged for optimum accessibility; the reach to the setting station centre is conveniently short to make workpiece handling easy. The tool loading station provides a very practical function: tools can be loaded while the spindle is running, so no time is wasted.



■ Helpful in day-to-day production: linear guideways provide smooth operation of the setting station doors.

Programming in the familiar system environment

Concentrated application know-how also forms the basis for the state-of-the-art high-end control technology incorporated in the H series.

The benefit to you: programming takes place in the well-known system environment with either SINUMERIK 840D solution line or Fanuc 310i-A. Both controls feature a nearly identical range of options. The basic configuration comprises the integrated safety functions, operating modes 2 and 3 and tool loading during spindle operation to save time.



■ Practical feature: the ergonomic operating panel is integrated into the guard panels.



■ Convenient: optional operating panel with display at the tool loading station.

Maintenance: done in a flash



Optimised life cycle costs

The acquisition costs are only one factor affecting the overall costs of a machine – another important aspect to consider are the maintenance costs. The H series features a number of innovations that provide a real benefit in terms of life cycle costs.

All function-relevant systems and components incorporated in the H series are installed within quick and easy reach. For example: components arranged for ease of maintenance and removable

guard panels provide access at the touch of hand. What is more, the Z-axis cover and the spindle can be replaced in no time at all thanks to the proven HELLER zero-spindle system. In most cases, maintenance and servicing or even repairs can be performed in a few easy steps. The quick response times of the HELLER spare parts service also help to keep production downtimes short. Service and maintenance points are limited to a few locations to allow for easy inspection and operation.

We are here for you. Worldwide. HELLER locations.

GERMANY

Gebr. Heller Maschinenfabrik GmbH
Gebrüder-Heller-Strasse 15
72622 Nürtingen
Telephone +49 7022 77-0
Telefax +49 7022 77-5000
sales@hnt.heller-machines.com

HELLER Services GmbH
Nürtingen
Gebrüder-Heller-Strasse 15
72622 Nürtingen
Telephone +49 7022 77-0
Telefax +49 7022 77-1200
services@hnt.heller-machines.com

HELLER Services GmbH
Chemnitz
Sandstrasse 116
09114 Chemnitz
Telephone +49 371 844949-0
Telefax +49 371 8449-2720
services@hdo.heller-machines.com

HELLER Services GmbH
Goslar
Vor dem Nordhees 12
38644 Goslar-Jerstedt
Telephone +49 5321 6834-0
Telefax +49 5321 6834-2199
services@hdm.heller-machines.com

HELLER Services GmbH
Hattingen
Hüttenstrasse 45
45527 Hattingen
Telephone +49 2324 9245-0
Telefax +49 2324 9245-2399
services@hdn.heller-machines.com

HELLER Services GmbH
Saarbrücken
Neumühlerweg 75
66130 Saarbrücken-Güdingen
Telephone +49 681 88372-0
Telefax +49 681 88372-2044
services@hdw.heller-machines.com

HELLER Services GmbH
Kirchheim
Paracelsusstrasse 3
73230 Kirchheim
Telephone +49 7021 80758-0
Telefax +49 7021 80758-2699
services@hdu.heller-machines.com

HELLER Services GmbH
Salem
In Oberwiesen 10
88682 Salem-Neufrach
Telephone +49 7553 91677-0
Telefax +49 7553 91677-2266
services@hds.heller-machines.com

HELLER Services GmbH
Nürnberg
Vogelweiherstrasse 33
Gebäude M4 – 2. Obergeschoss
90441 Nürnberg
Telephone +49 911 400896-0
Telefax +49 911 400896-2819
services@hdf.heller-machines.com

BRAZIL

HELLER Máquinas Operatrizes
Indústria e Comércio Ltda.
Rua Joaquim Machado, 250
Bairro Aparecidinha
Caixa Postal 126
18087-280 Sorocaba - São Paulo
Telephone +55 15 2103-3000
Telefax +55 15 2103-3032
vendas@hbr.heller-machines.com

CHINA

HELLER Machinery & Trading (Shanghai) Co., Ltd.
Rm. 4402-4403, Shanghai Maxdo Centre
No. 8 Xing Yi Road
HongQiao Development Zone
200336 Shanghai
Telephone +86 21 52080485
Telefax +86 21 52080495
sales@heller-machinetools.com.cn



Gebr. Heller Maschinenfabrik GmbH
 Beijing Representative Office
 Chaowai SOHO, Building D, Room 1203
 Chaowai Street 6B
 Chaoyang District
 100022 Beijing
 Telephone +86 10 59003652
 Telefax +86 10 59003752
 sales@heller-machinetools.com.cn

FRANCE

HELLER Machines Outils SAS
 Parc d'Activités des trois Noyers
 15, Avenue James de Rothschild
 Ferrières en Brie
 77614 Marne la Vallée Cedex 3
 Telephone +33 1 60 94 20 70
 Telefax +33 1 60 94 20 72
 ventes@hfr.heller-machines.com

GREAT BRITAIN

HELLER Machine Tools Ltd.
 Acanthus Road
 Ravensbank Business Park
 Redditch, Worcs. B98 9EX
 Telephone +44 121 275-3300
 Telefax +44 121 275-3380
 sales@huk.heller-machines.com

ITALY

HELLER Italia Macchine Utensili S.r.l.
 Via Galileo Galilei 6
 37029 San Pietro in Cariano
 Verona
 Telephone +39 045 6838510
 Telefax +39 045 6838530
 vendite@hit.heller-machines.com

MEXICO

HELLER Machine Tools de Mexico
 S. de R.L. de C.V.
 Cortazar No. 102 – Col. Hidalgo
 C.P. 37329 Leon, Gto.
 Telephone +1 248 288-5000
 Telefax +1 248 288-9560
 sales@hus.heller-machines.com

SLOVAKIA

HELLER Services s.r.o.
 Hlavná 1409 / 48
 95201 Vráble
 Telephone +421 37 776-8300
 Telefax +421 37 776-8309
 services@hsk.heller-machines.com

SPAIN

HELLER Iberica Machine Tools, S.L.
 Antic Cami de Caldes, 1 b
 08480 L'Ametlla del Vallès
 Barcelona
 Telephone +34 93 8430209
 Telefax +34 93 8430333
 ventas-iberica@heller.de

USA

HELLER Machine Tools L.P.
 1225 Equity Drive
 Troy, Michigan 48084
 Telephone +1 248 288-5000
 Telefax +1 248 288-9560
 sales@hus.heller-machines.com